



TouchChat[®] Express Manual

TouchChat Express 10 · 2nd Generation

Dedicated and Non-Dedicated Devices
English Version



DOC100276v100

Copyright and Trademark Information

© 2024 PRC-Salttillo. Non-commercial reprint rights for clinical or personal use granted with inclusion of copyright notice. Commercial use prohibited; may not be used for resale. Contact PRC-Salttillo for questions regarding permissible uses.

AAC Coaching Corner™, AAC Language Lab®, AAC Learning Journey™, Accent®, AeroSwitch®, AeroText™, ChatEditor™, ChatFusion™, ChatPoint™, ChatSMS®, ChatWrap®, CoreScanner™, Dialogue®, Empower®, Engage®, Essence®, Freedom Switch™, iSharePRC®, LAMP™, LAMP Words for Life®, Look®, Minspeak®, NovaChat®, NuEye®, NuPoint®, NuVoice®, PASS™, PRiO®, Realize Language™, Semantic Compaction®, Timocco-on-Accent™, TouchChat®, UNIDAD®, Unity®, VersaChat™, VersaEye™, VersaSpeaker™, VersaWrap™, Via®, VocabPC™, and Xtreme™ are trademarks of PRC-Salttillo.

Acapela Group® and my-own-voice™ are trademarks of Acapela Group. Acapela Group, Copyright 2024. All rights reserved. Used with permission. The Acapela text to speech technology and the synthetic voices contained in this software are included free of charge for the usage by the end user but may be used solely for communication purposes and may not be sold, copied or otherwise exploited for any type of profit.

AirDrop®, App Store®, Apple®, Apple Books®, FaceTime®, Guided Access®, iCloud®, iPad®, iPad Air®, iPad mini®, iPadOS®, iPad Pro®, iPhone®, iPod®, iTunes®, Lightning®, Mac®, Macintosh®, Safari®, Siri®, TouchID®, and TrueDepth® are trademarks of Apple Inc., registered in the U.S. and other countries and regions.

The *Bluetooth®* word mark and logos are registered trademarks owned by the Bluetooth SIG, Inc. and any use of such marks by PRC-Salttillo is under license.

CAVIWIPES™ is a trademark of Metrex Research LLC.

Dropbox® is a registered trademark of Dropbox, Inc.

Google™, Google Docs™, Google Drive™, Google Play™, Android™, Chromebook™, Gmail™, and YouTube™ are trademarks of Google Inc.

Intel®, the Intel logo, Intel® Core™, and Celeron® are trademarks of Intel Corporation or its subsidiaries.

iOS® is a trademark or registered trademark of Cisco in the U.S. and other countries and is used under license.

Ivona is supplied by ReadSpeaker.

Microsoft® and Windows® are either registered trademarks or trademarks of Microsoft Corporation in the United States and/or other countries.

My QuickChat™ is copyright of Talk To Me Technologies.

Netflix® is a trademark of Netflix, Inc.

PCS® is a trademark of Tobii Dynavox LLC. All rights reserved. Used with permission.

Samsung® and Galaxy Tab® are registered trademarks of Samsung Electronics America, Inc.

The symbols used in this work are owned by n2y, LLC. Used with permission under license. © 2024.

TIK TOK is a trademark of Bytedance Ltd.

Velcro® is a registered trademark of Velcro BVBA.

VocaliD™ is a trademark of VocaliD, Inc.

The Voice Keeper and Almagu voices are intellectual property of Almagu.

WHATSAPP is a trademark of WHATSAPP LLC.

Wi-Fi® is a registered trademark of Wi-Fi Alliance.

Windex® is a registered trademark of S. C. Johnson & Son, Inc.

WordPower® is a trademark of Inman Innovations, Inc. © 2001-2024; All rights reserved. Used with permission.

Other trademarks are the property of their respective owners.

Document Version/Models

DOC100276v100- 10/06/2024

Applies to model TCE10.2; dedicated and non-dedicated devices

Contents

Device Overview	4
Getting Help	4
Device Features	5
Turning the iPad On and Off or Putting It to Sleep	6
Turning the iPad On and Off	6
Locking the iPad and Putting It to Sleep	6
Turning the Amplifier On and Off	7
Adjusting the Volume and Muting Sounds	8
Using the Touchscreen	9
Using the Home Button and Home Screen	9
Attaching a Strap	10
Positioning the Stand	12
Removing the Handle	12
Attaching a Wheelchair Mounting Plate	13
Replacing the Rubber Boot	14
Charging the Device and Amplifier	15
Cleaning and Disinfecting Your Device	17
Routine Cleaning and Disinfecting	17
Disinfecting TouchChat Express and Accessories for Multiple Users	18
Troubleshooting	19
Specifications	20
Safety Information	21
Compliance Information	23
International Contact Information	26

Device Overview

TouchChat® Express devices feature a reusable, protective case. The rubber boot and plastic shell provide protection while the amplifier delivers high quality audio output. The handle provides optimal portability. This manual offers step-by-step instructions for working with the TouchChat Express device.

Getting Help

For information on using the TouchChat app, go to <https://touchchatapp.com/manuals-and-qrgs>.

If you need assistance using or maintaining your device or if you experience problems, please contact us by phone or email.

Phone: 1-800-382-8622

Email: service@salttillo.com

Trouble Tickets: <https://salttillo.com/tt/>

Device Features

Rear View

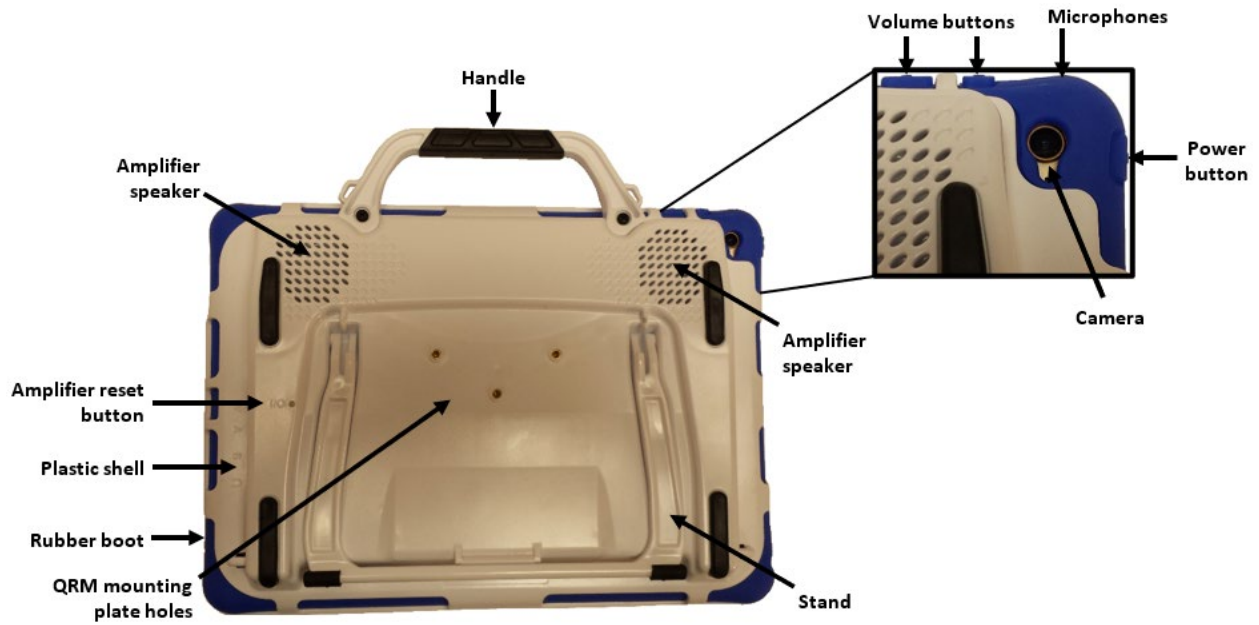

Front View



Side View

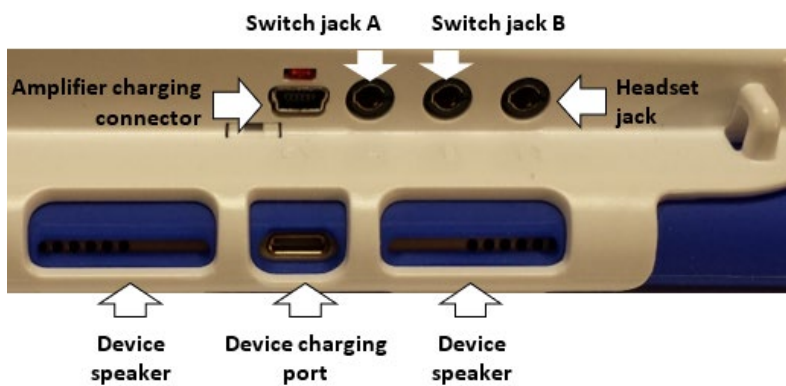

Turning the iPad On and Off or Putting It to Sleep

This section applies to non-dedicated devices only.

The power button allows you to turn the iPad on and off or lock the iPad and put it to sleep.



Turning the iPad On and Off

To turn the iPad on, hold down the power button until the Apple® logo appears on the screen.

To turn the iPad off, hold down the power button for a few seconds until “slide to power off” appears on the screen. Then drag the **slide to power off** text.

Locking the iPad and Putting It to Sleep

You can lock the iPad and put it to sleep when you are not using it. Locking the iPad turns off the display, turns off touch capability, and saves battery power. The iPad is still able to receive calls, text messages, alarms, and notifications. You can also listen to music and adjust the volume.

To lock the iPad:

To lock the iPad, press the power button. If you do not touch the screen for two minutes, the iPad will lock automatically. To change the auto-lock time, choose **Settings > Display & Brightness > Auto-Lock**.

To unlock the iPad:

TouchChat Express 8: Press the **Home** button or the power button.

TouchChat Express 10: Press the **Home** button or the power button, and then drag the **slide to unlock** text that appears on the screen.

To add a passcode:

If you want to require a passcode to unlock the iPad, choose **Settings > Touch ID & Passcode**. Then use the passcode options to set the passcode.

Turning the Amplifier On and Off

The device and amplifier communicate using a Bluetooth® connection. Typically, the amplifier should be left on. During air travel and in some medical facilities the Bluetooth option is required to be turned off. When the amplifier is off, speech is still present but comes from the device's internal speaker.

Turning Bluetooth Off (Non-Dedicated Devices)

1. Open the device's **Settings** menu.
2. Turn **Bluetooth** off.

Turning Bluetooth On (Non-Dedicated Devices)

1. Open the device's **Settings** menu.
2. Turn **Bluetooth** on.
3. Choose the amplifier from the list of options under "Devices" to the right of "Bluetooth".
4. Close the Settings menu.
5. The blue light on the edge of the amplifier should be solid blue.

Connecting Bluetooth to the TouchChat Software

1. Open the TouchChat app.
2. Open your vocabulary file and choose **Menu > Settings**.
3. Scroll down to the Amp Connect section.
4. Choose **Select Amp** and choose your amplifier.

Turning the Amplifier On and Off

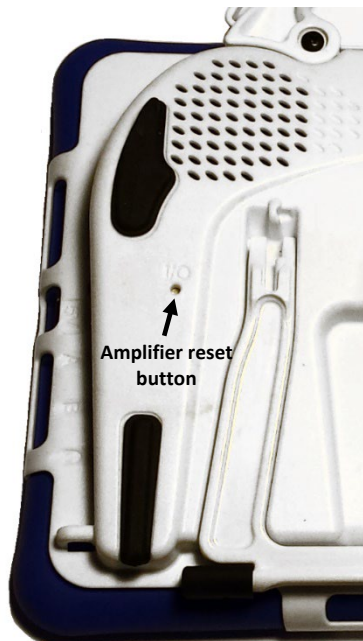

To turn the amplifier off: Press and hold the amplifier reset/power button (labeled "I/O") until both the amber and blue lights come on. When the amber light goes out, let go of the button.

Hint: The button is recessed. Use the tip of a pen when you need to press it. Do **not** use an object with a sharp point, such as a pin; it could damage the button.

To turn the amplifier on: Press the reset/power button for a second. The blue light will flash to indicate the amplifier is on.

If the speakers/amplifier no longer produce sound or sound is limited to the device's speakers only:

- Make sure the amplifier has been charged.
- Check the blue LED on the side of the amplifier. If it is flashing, the amplifier needs to be reconnected.
- Make sure Airplane Mode is off.

Adjusting the Volume and Muting Sounds

 Excessive volume or sound pressure level when using earphones or headphones can cause hearing loss over extended periods of time.

Using the Volume Buttons

The volume buttons are located on the edge of the device. Pressing one button increases the volume and pressing the other lowers the volume.

The volume buttons fit into a slot in the TouchChat Express plastic shell. The rubber boot for some models covers the two volume buttons with a single button. Press one side of the button to increase the volume and press the other side of the button to decrease the volume. By pressing a side, you are pressing the device button underneath.

To mute sound, press and hold the Volume Down button.

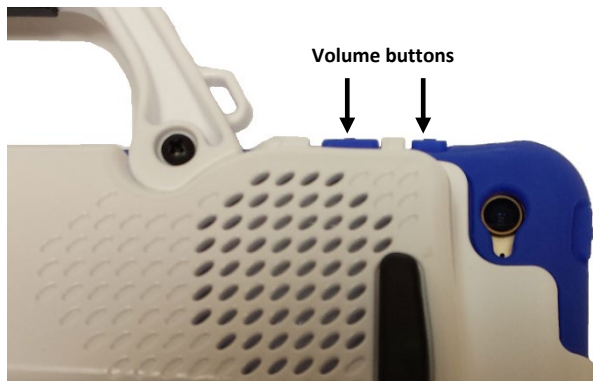

Using the Touchscreen

Your device comes with a capacitive touchscreen. It responds best to a light touch from the pad of your finger.

Important! Using excessive force or a metallic object when pressing on the touchscreen may damage the tempered glass surface.

Stylus

A stylus was provided in your TouchChat Express package. If you prefer to get your own stylus, it must be compatible with a capacitive touchscreen.



Note: The stylus provided has an opening on the end for attaching to you or the device. Find a chain, string, or lanyard that matches your personal style.

 The stylus is a potential hazard for poking an eye.

Using the Home Button and Home Screen

This section applies to non-dedicated devices only.

Press the Home button to display the Home screen at any time.



All the apps that came on your iPad, plus any apps you download, are available from the Home screen. To open an app, simply tap it. To see the apps that you have opened, double-press the **Home** button and swipe left or right. To display the Home screen at any time, press the **Home** button. Swipe left or right to go to other screens.

- To use Siri® (on iPad 3rd generation or later), press and hold the **Home** button.
- You can also press the **Home** button quickly three times to turn accessibility features on or off.
- To take a screen shot, press and hold the power button and **Home** button at the same time.

Note: On iPad models with Touch ID®, you can use the sensor in the Home button, instead of using your passcode or Apple ID password, to unlock the iPad or make purchases in the iTunes Store, App Store, and iBooks Store. You can also use the Touch ID sensor for authentication when using Apple Pay to make a purchase from within an app.

Attaching a Strap

If You Received Loops with Your Strap:

Your package included a strap and two loops for attaching the strap. Do not attach a strap directly to the plastic case as this may damage the device.

⚠ The loops are potential choking hazards. Use them with caution.

Decide whether you want to carry the unit in landscape or portrait orientation. Attach two loops to the appropriate side as shown.



Step 1: Feed the end of the loop through the hole in the case.



Step 2: Thread the metal ring through the loop.



Step 3: Pull the metal ring to tighten the loop.

Step 4: Attach the connectors on the ends of the strap to the metal rings on the loops.

If You Received Metal Rings with Your Strap:

Your package included a strap and two metal rings for attaching the strap. Do not attach a strap directly to the plastic case as this may damage the device. For devices that include a handle, simply attach the strap to the bottom holders if you remove the handle.

⚠ The metal rings are potential choking hazards. Use them with caution.

Decide whether you want to carry the device in landscape or portrait orientation. Attach two metal rings to the appropriate side as shown.



Step 1: Open the ring as you would open a key ring. *Suggestion:* Use your fingernail, a screwdriver, or a dime.



Step 2: Push the open ring onto the holder in the case.



Step 3: Allow the ring to close on the holder.



Step 4: Clip the shoulder strap to the ring.

Positioning the Stand

Your device comes with a stand that can be positioned for easy viewing. When closed, the stand is held in place by a latch.

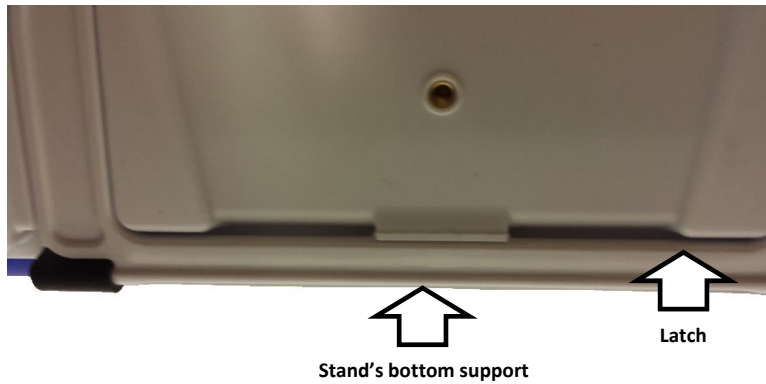

To position the device at an angle for easy viewing of the screen, do the following:

1. Place the device face-down on a flat surface.
2. While holding your thumb on the edge of the device below the stand's bottom support, press on the **inside** of the support with the tip of your index finger (or the tips of several fingers) to pull the support **away** from the latch.
3. Lift the support away from the back of the device until the legs latch into place. Then position the device.



Removing the Handle

If you do not plan to use the handle, you can remove it by removing the screws that hold it in place.



⚠ The handle and screws are potential choking hazards.

Attaching a Wheelchair Mounting Plate

Three threaded holes are provided on the back of the device for attaching an optional wheelchair mounting plate. If you purchased the wheelchair mounting plate accessory, follow these instructions to attach the plate to your device.



1. Place the device face-down on a flat surface. Be careful not to scratch the display.
2. Align the three tapered holes in the mounting plate with the three threaded holes on the back of the device.

Important! Be sure that the mounting plate is oriented so that the additional hole for the holding pin is in the upper left.

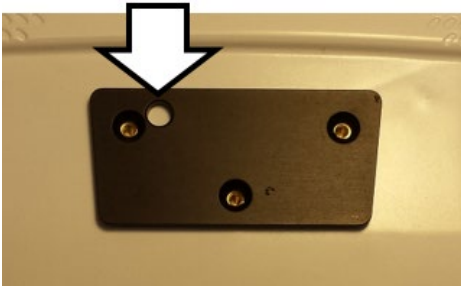

3. Insert and tighten the screws.



Replacing the Rubber Boot

To replace the rubber boot, follow these instructions.

1. Remove the existing plastic shell/rubber boot assembly from the device.
2. Remove the existing boot from the shell.
3. Fit one end of the device into the replacement rubber boot. Be sure to line up the buttons and ports on the device's sides with the corresponding receptacles and openings in the boot.

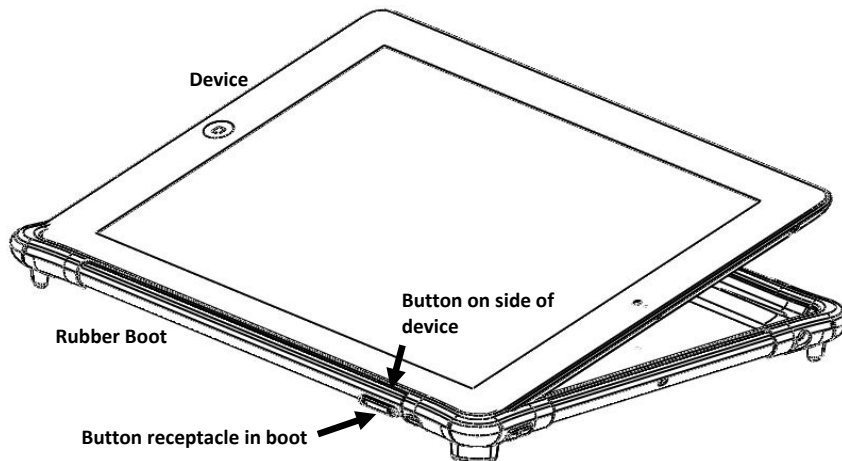

4. When you are sure that the device and boot are properly aligned, push the device down into the boot and pull the edges of the boot over the sides until the device is fully “wrapped” in the boot on all sides.
5. Fit one end of the device—wrapped in the boot—into the shell. Be sure to line up the buttons and ports on the device's sides with the corresponding openings in the shell.

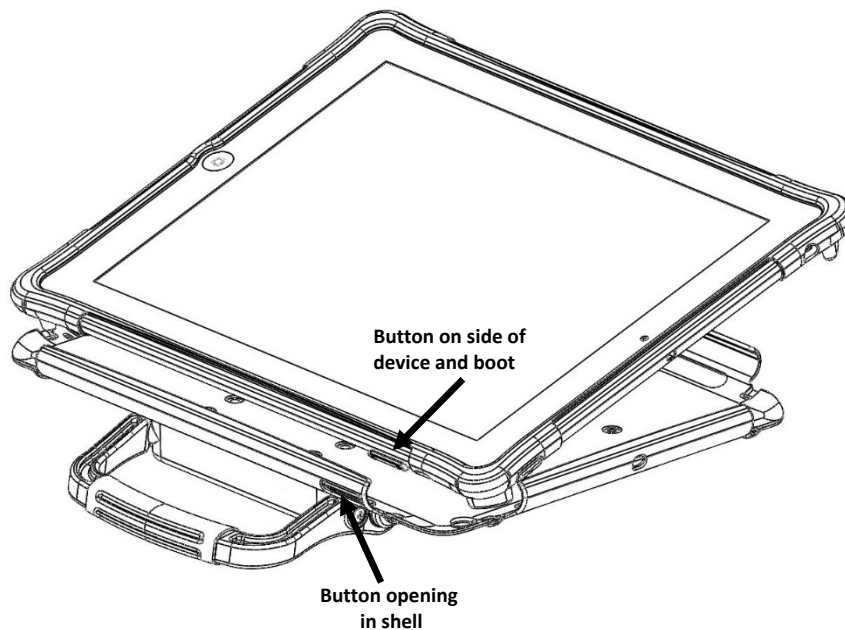

6. When you are sure that the device/boot assembly is properly aligned, carefully push each side into the shell until all sides snap into place.

Charging the Device and Amplifier

Connecting the Charger

You received a battery charger with your TouchChat Express. One end of the charger plugs into a wall outlet—a surge protector is recommended. The other end has two connectors, allowing you to charge the device and amplifier at the same time.



- One connector plugs into the amplifier.
- The other connector is a receptacle for the USB cable that came with your device.

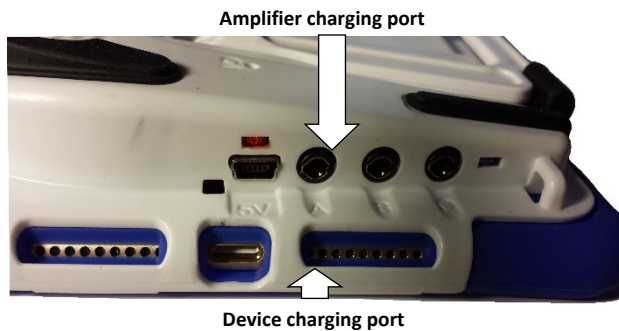

- ⚠ Use only the battery charger or backup charger provided with your device.
- ⚠ Cords and cables are potential entanglement or strangulation hazards. Please consider this prior to placing these items with device users.
- ⚠ Locate the device in a safe location while charging.
- ⚠ Batteries are not replaceable by the customer.

Using the Backup Charger

A backup charger came with your device. Use that charger only if necessary in an emergency. The backup charger can only be used with the device. Do not use it to charge the amplifier.

To charge the device and amplifier:

Hint: We suggest charging both the device and the amplifier each night.

1. Tap the device's power switch to turn the display light off.
2. Plug the charger's amplifier connector into the amplifier.
3. Plug one end of the USB cable that came with your device into the device and the other end into the charger's receptacle.
4. Plug the other end of the charger into a wall outlet or surge protector.
5. The amber light next to the amplifier's charging port will flash during charging and remain on when the amplifier is fully charged.

When the device and amplifier are fully charged:

1. Unplug the connectors from the device and amplifier.
2. Unplug the charger from the wall outlet or surge protector (*optional*).
3. Tap the device's power switch to turn the display light on.

Checking Battery Status of the Device Only

To check the battery level or charging status of a non-dedicated device, press the **Home** button. The current battery status is displayed in the top right corner of the screen. The battery status indicator only shows the battery level or charging status of the iPad, not the amplifier.

Extending Battery Life

To extend the battery life of a non-dedicated device, you can dim the screen. Choose **Settings > Display & Brightness** and drag the slider.

Disposing of the Device or the Amplifier Battery

 **Device Disposal:** Please dispose of your device in accordance with your local, state, and/or federal electronic recycling laws.

 **Battery Disposal:** If the battery in your amplifier needs to be replaced, dispose of the old battery in accordance with your local, state, and/or country regulations.

Cleaning and Disinfecting Your Device

If your TouchChat Express will only be used by one person, routine cleaning and disinfecting should be sufficient. If, however, more than one person will be using the unit, take additional measures to clean and disinfect the unit after it has been used by one person before allowing it to be used by another.

Routine Cleaning and Disinfecting

Important! Do not use solvents or abrasives or spray water or cleaner on the unit.

Cleaning the touchscreen

The touchscreen is very sensitive. Fingerprint smears, dust, grime, saliva, etc. will affect its performance. The screen also reacts to raindrops and extremes in temperature (condensation).

To dust the touchscreen, use a soft, lint-free cloth. For heavier cleaning, use a slightly dampened, lint-free cloth and then dry the screen with another soft, lint-free cloth.

Cleaning the TouchChat Express components and keyguard

The unit can be disassembled and the TouchChat Express components and keyguard washed in hot, soapy water. Dry them thoroughly before reassembling the unit. The best practice for regular cleaning is to dry accessories by hand, lay them on a dry towel, and let them air dry for about 5 minutes before placing them back on the device.

Disinfecting

To disinfect everything but the display, use a solution of vinegar and water ($\frac{1}{4}$ cup vinegar to 1 cup water). Wipe the rubber boot (not the display) using a cloth dampened with this solution.

Wash the plastic shell and keyguard separately with the vinegar and water solution. Allow all equipment to air dry. **Do not use vinegar and water on the display!**

What about drooling/saliva?

Any saliva should be wiped up immediately, especially on the touchscreen or around any of the connectors. Use a slightly dampened, lint-free cloth to wipe the device.

What about spills, rain, or accidental immersion?

If you spill liquid or any runny substance on your TouchChat Express; if you are caught in a downpour; or if the unit is accidentally dropped in liquid, immediately dry the components as thoroughly as possible. Try using the device. If it does not work, call Saltillo technical support and tell them what happened. They may ask you to send in your device for servicing.

Disinfecting TouchChat Express and Accessories for Multiple Users

This section applies only when more than one person will be using the same unit. In that situation, it is vital to effectively disinfect the unit and accessories that have been used by one person before allowing them to be used by another.

First Step: Put on protective gloves

Next Step: Clean the TouchChat Express components and accessories

1. Wipe down the TouchChat Express components and accessories with disinfectant wipes (Virucidal, Bactericidal, Pseudomonacidal, Tuberculocidal, Fungicidal)—Metrex CaviWipes™. Follow the disinfectant product manufacturer's instructions for *cleaning*.
2. Take a Q-tip with cleaner applied (for example, Windex® or another commercial cleaner) and clean inside all cracks and crevices. You may want to use a toothbrush or similar brush.
3. Blow the components off with an air hose, or wipe it dry.

Important! Make sure all soil is removed from the TouchChat Express components and accessories. This is vital before proceeding to disinfecting the equipment.

Next Step: Disinfect the TouchChat Express components and accessories

1. Wipe down the TouchChat Express components and accessories with a new disinfectant wipe (Virucidal, Bactericidal, Pseudomonacidal, Tuberculocidal, Fungicidal)—Metrex CaviWipes. Follow the disinfectant product manufacturer's instructions for *disinfecting*.
2. Make sure to clean inside all cracks and corners, and wipe more than once if necessary to keep the components wet for a minimum of three (3) minutes.
3. Allow the components and accessories to dry.

Final Step: Wipe the touchscreen

1. When the TouchChat Express components and accessories are dry, wipe down the viewing area (device touchscreen, keyguard, etc.) with glass cleaner, so the screen does not discolor.
2. Allow the equipment to dry.

Troubleshooting

Speakers/amplifier no longer produce sound. / Sound is limited to the device's speakers only.

First try this: Make sure the amplifier has been charged. If the amplifier is charged ...

Next try this: Make sure Airplane Mode is off. Press the device's **Home** button and choose **Settings**. If Airplane Mode is on, turn it off.

Then try this: Check the blue LED on the side of the amplifier. If it is flashing, the amplifier needs to be reconnected. Choose **Settings** > **Bluetooth** and select the Bluetooth identifier from the Bluetooth "Devices" list.

Amplifier battery status is not displayed with device battery status

Select **Menu** and **Settings** and then scroll to the connections. The amplifier setting should show **Connected**. If it does not, select the setting and select your device's amplifier.

Specifications

Weight

1.95 lbs.

Dimensions

9 11/16 in. x 6 15/16 in. x 1 ¼ in.

Battery life

10-12 hours, depending on individual usage and power settings

Software/operating system

Various apps/iPadOS or iOS

Standard components

Amplifier, handle, stand, boot, battery charger/USB cable, stylus

Accessories

Keyguards, TouchGuides, wheelchair mounting plate, backpack carrying case, shoulder strap, waist belt, strap attachments

Operating Environment

Ambient temperature 5°C to 40°C (41°F to 104°F)

Relative humidity 15% to 93%, non-condensing

Atmospheric pressure 70 kPa to 106 kPa

The device needs to be protected from moisture during use.

Transport and Storage Environment

While in transport or storage, the range of temperatures to which the device can be exposed is -25°C (-13°F) without relative humidity control to 70°C (158°F) at a relative humidity up to 93%, non-condensing, with an atmospheric pressure range of 70 kPa to 106 kPa.

Temperature Conditions for Direct Contact

At an ambient temperature of 40°C (104°F), the surface temperature of the back of the device can increase as much as 11°C (51.8°F) during charging to a temperature of 51°C (123.8°F). For this reason, minimize contact with the back of the device while the device is charging.

- ⚠ While the device is charging, touching the surface of the device with broken skin may aggravate a wound.
- ⚠ While the device is charging, infants or high-risk groups should not touch the surface of the device if there is a chance of burning the skin.
- ⚠ While the device is charging, minimize contact with the back of the device.

Safety Information

Emergencies

- ⚠ This device is not intended to be an emergency call device or sole communication aid.

Modifications

- ⚠ Do not attempt to modify the device or any accessories. Modifications could create a safety hazard and make the equipment inoperative.

Cleaning, Maintaining, and Servicing

- ⚠ Do not service or maintain the device while in use. Disconnect the charger and turn off the device before cleaning.
- ⚠ If the device or an accessory is damaged, call Service for assistance. Do not attempt to make repairs yourself.

Accessories

- ⚠ Do not use accessories, detachable parts, or materials not described in the manual.
- ⚠ Do not use accessories, detachable parts, or materials in any other way than described in the manual.

Mounting and Positioning

- ⚠ Mounts used should be fitted by a qualified person. Failure to install the mounting system according to the manufacturer's instructions may result in injury to the user. Ensure the user's view is not obstructed by the mounting.
- ⚠ Analysis of positioning by a qualified person is required to prevent repetitive stress injuries to the user.

Vision and Hearing

- ⚠ The communication partner should ensure that the user takes frequent breaks to avoid eye strain.
- ⚠ Consult your vision care provider about device positioning considerations for the user.
- ⚠ Excessive volume or sound pressure level when using earphones or headphones can cause hearing loss over extended periods of time. Set the volume to a low level and increase it only enough that you can hear comfortably.

Ports and Connectors

- ⚠ Keep ports and connectors clean to maximize the service life of the device. Dirty cable connectors transfer contamination to the mating connector on the device and may degrade performance.
- ⚠ If the device has been exposed to water, each USB port must be completely dry before a USB cable is inserted into it. To remove moisture from the USB ports, shake the device several times with each USB port facing downward, and then use a microfiber cloth to wipe the device dry. You should then check the USB port area again. If moisture is still visible in any USB port, repeat the shaking and drying procedure.
- ⚠ Do not try to force a connector into a port. Be sure to insert the connector into the correct port and that the connector is turned so that it matches the orientation of the port.

Small Parts, Cords, Cables, and Straps

- ⚠ Cords, cables, and straps are potential entanglement or strangulation hazards. Consider this prior to placing these items with device users.
- ⚠ On a regular basis, visually inspect cables, cords, and connectors for damage or wear, especially where they are subject to extra stress. Cables and cords can become frayed or damaged from heavy use or with age. For example, a frayed cable could cause a battery charger/power adapter to short-circuit, posing a hazard to the user. If any cable, cord, or connector is damaged or worn, call Service for a replacement.
- ⚠ When unplugging a cable or cord, grasp the connector instead of the cable or cord itself to avoid damage or wear.
- ⚠ Always use cables, for charging or transferring vocabulary files, according to the instructions in the manual.
- ⚠ Small parts could present a choking or other hazard.
- ⚠ If the stand is removed, it becomes a potential hazard for poking an eye. Closing the stand could pinch a finger.
- ⚠ The stylus is a potential hazard for poking an eye.

Screen

- ⚠ Do not use the device if the screen is cracked or broken.

Interference

- ⚠ When operating this device in a medical environment, do not use it with any product that is not medically approved. Follow all rules for appropriate wireless device use.
- ⚠ Do not use this device close to sources of RF/RFID radiation or you may encounter interference. Move away, if possible, from the source of the interference.

Water

- ⚠ If the device has been exposed to water, each USB port must be completely dry before a USB cable is inserted into it. To remove moisture from the USB ports, shake the device several times with each USB port facing downward, and then use a microfiber cloth to wipe the device dry. You should then check the USB port area again. If moisture is still visible in any USB port, repeat the shaking and drying procedure.
- ⚠ This device is intended for use in normal communication situations. It is not waterproof. Do not spray or splash liquid directly on the device and use extreme caution when using it around water. As with most electronic devices, you should never use the device when you are actually in the water (for example, a pool or bath).

Batteries and Charging

- ⚠ Use only the battery charger provided with this device.
- ⚠ Do not place the device where it is difficult to operate or difficult to disconnect from the charger.
- ⚠ Always follow the instructions in the manual when charging the device.
- ⚠ Do not insert any object into the charging port. This can result in damage to the port.
- ⚠ To avoid electric shock and damage to the device, do not charge the device while it is wet or in an area where it could get wet. Do not handle the device, charger, or cords with wet hands.
- ⚠ Locate the device in a safe, dry location while charging. Do not charge the device outdoors.
- ⚠ Keep the charger away from water and do not allow water or any other liquid to spill on it.
- ⚠ If the charger or charger cord is damaged, call Service for a replacement.

Heat

- ⚠ Do not place the device in an appliance such as a microwave or oven, near an open flame, or on or near a source of heat such as a stove or heater.
- ⚠ Do not leave the device in a hot vehicle for a prolonged period.

Oxygen-Rich Environment

- ⚠ Do not take the device into an oxygen-rich environment (operating room, oxygen tent, etc.).

Touching the Surface

- ⚠ While the device is charging, touching the surface of the device with broken skin may aggravate a wound.
- ⚠ While the device is charging, high-risk groups should not touch the surface if there is a chance of burning the skin.

Implantable Medical Devices

A minimum of 6 inches should be maintained between a handheld wireless device and an implantable medical device, such as a pacemaker, implantable cardioverter defibrillator, vagus nerve stimulator, shunt, or stent, to avoid potential magnetic interference with the medical device. A person who has an implantable medical device:

- ⚠ should always keep the device a minimum of 6 inches from their implantable medical device;
- ⚠ should not carry the device in a breast pocket;
- ⚠ should move the device away from themselves if they suspect it is interfering with the implantable medical device;
- ⚠ should read and follow the directions from the manufacturer of the implantable medical device. If you have any questions about using your wireless device with an implantable medical device, consult your health care provider.

Compliance Information

Federal Communications Commission (FCC) Warning

This device complies with part 15 of the FCC Rules. Operation is subject to the following two conditions: (1) This device may not cause harmful interference, and (2) this device must accept any interference received, including interference that may cause undesired operation.

Changes or modifications to this device not expressly approved by PRC-Salttillo could void the user's authority to operate the equipment.

Note: This equipment has been tested and found to comply with the limits for a Class B digital device, pursuant to Part 15 of the FCC Rules. These limits are designed to provide reasonable protection against harmful interference in a residential installation. This equipment generates, uses and can radiate radio frequency energy and, if not installed and used in accordance with the instructions, may cause harmful interference to radiocommunications. However, there is no guarantee that interference will not occur in a particular installation. If this equipment does cause harmful interference to radio or television reception, which can be determined by turning the equipment off and on, the user is encouraged to try to correct the interference by one or more of the following measures:

- △ Reorient or relocate the receiving antenna.
- △ Increase the separation between the equipment and receiver.
- △ Connect the equipment into an outlet on a circuit different from that to which the receiver is connected.
- △ Consult the dealer or an experienced radio/TV technician for help.

Innovation, Science and Economic Development Canada (ISED) Warning

This device complies with Innovation, Science and Economic Development Canada license-exempt RSS standard(s). Operation is subject to the following two conditions: (1) This device may not cause interference, and (2) This device must accept any interference, including interference that may cause undesired operation of the device.

Le présent appareil est conforme aux Innovation, Sciences et Développement économique Canada (ISDE) applicables aux appareils radio exempts de licence. L'exploitation est autorisée aux deux conditions suivantes: (1) l'appareil ne doit pas produire de brouillage, et (2) l'utilisateur de l'appareil doit accepter tout brouillage radioélectrique subi, même si le brouillage est susceptible d'en compromettre le fonctionnement.

Canadian PMN

This product includes BGM220P22A.

FCC RF Radiation Exposure and SAR Statements

This device has been tested for body-worn Specific Absorption Rate (SAR) compliance. The radio module has been evaluated under FCC Bulletin OET 65C (01-01) and found to be compliant to the requirements as set forth in CFR 47 Sections, 2.1093, and 15.247 (b) (4) addressing RF Exposure from radio frequency devices. This model meets the applicable government requirements for exposure to radio frequency waves. The SAR limit set by the FCC is 1.6 W/kg.

Wireless Communications Equipment

Wireless communications equipment such as wireless home network devices, mobile phones, cordless telephones and their base stations, and walkie-talkies can affect this device and should be kept a least six inches away from the device.

Limitation of Intended Use, Third Parties, and Data Loss

PRC-Salttillo does not warrant any functionality of this speech generating device outside the terms of its express warranty relating to the intended use of speech generation. PRC-Salttillo does not warrant any third-party software, nor is it responsible for any injury, damage or claims arising from the function or malfunction of any third-party technology, websites, products, and software. Additional uses may require further clinical determinations beyond the scope of an evaluation for speech generation devices.

PRC-Salttillo assumes no responsibility for any loss or claims by third parties which may arise through the use of this product.

PRC-Salttillo assumes no responsibility for any damage or loss caused by the deletion of data as a result of malfunction repairs or battery replacement. Be sure to back up all important data on other media (computer) to protect against its loss.

Device Intended Purpose

This device is a speech generating device that augments communication for an individual with speech/language impairment. This device and its language programs give the user the ability to initiate conversation, seek information, state opinions, and share feelings. Depending on the model, it can be hand-held, used with a table stand, or mounted to a wheelchair; and can be accessed by using the touchscreen, and available eye tracking system or head tracking system, or a variety of available switch accessories. The device does not incorporate in any way medicinal substances, human blood or plasma derivatives, nor is it manufactured using tissues of animal origin.

Indications and Contraindications

Indication: This device is a speech generating device that augments communication for an individual with speech/language impairment.

Contraindication: This device is not intended to be an emergency call device or sole communication aid.

Existing Application Risks

No existing application risks are known.

Expected Service Life

The expected service life of the device, battery charger, and accessories is five years. If you dispose of your device, battery charger, or accessories, please dispose of them in accordance with your local, state, and/or country electronic recycling laws.

Intended Operators

The individual using the device to communicate, the individual's communication partner, and/or the person changing device settings, maintaining software files, etc. are the intended operators of the device. The pictures and text in this document will help these operators achieve the intended use of the device.

Expected Position of Operators

In normal use, the device is expected to be within 12 to 14 inches of the individual's body. The distance will vary according to whether the device is hand-held or mounted on a wheelchair or table.

Special Skills, Training, or Knowledge Required

No special skills or training are required to operate or maintain the device. The pictures and text in this document will help the operators acquire the knowledge to achieve the intended use of the device.

Instructions for Use

- △ All functions of the device are safe for use by the user. For best results, follow the instructions in the manual.
- △ There is no need to turn the device or amplifier off when using the device on a daily basis. It is recommended to restart the device once per week and put it to sleep daily.
- △ To report any serious incident associated with the device, contact PRC-Salttillo and your national authority.
- △ For information on cleaning the device, see the device manual.

Contact Information for Help

If you need assistance in setting up, using, or maintaining your device or if you need to report unexpected operation of the device or an unexpected event related to the device, please contact PRC-Salttillo's Service department at 1-800-382-8622 or at service@salttillo.com.

Instructions for Storage

If you will be leaving the device in storage for a long period of time, turn the device and amplifier off. Devices in storage must be charged every six months.

Classifications

Protection against electrical shock: Class II / internally powered

Mode of operation: Continuous

Type of applied part: BF

Explanation of Symbols on PRC-Salttillo Devices, Accessories, or Packaging



The device is Federal Communications Commission (FCC)-compliant.



The device conforms to European Union health, safety, and environmental standards.



The device conforms to the requirements of the UK MDR 2002.



The device complies with Innovation, Science and Economic Development Canada license-exempt RSS standard(s).



The entire device and accessories, excluding the adapter, are type BF applied parts. “Applied part” refers to the part of the device with which the user comes into physical contact when using it for its intended function.



The device complies with applicable ACMA technical standards for telecommunications, radiocommunications, EMC, and EME.



Caution! Use caution when operating the device to avoid undesirable consequences.



The device emits generally elevated, potentially hazardous, levels of non-ionizing electromagnetic radiation.



Recycle electronic equipment. Do not throw the device in the trash.



The device is protected against ingress of solid objects and water.



Keep dry. The device needs to be protected from moisture.



The range of temperatures to which the device can be exposed while in use, transport, or storage.



The range of humidity to which the device can be exposed while in use, transport, or storage.



The range of atmospheric pressure to which the device can be safely exposed while in use, transport, or storage.



Refer to the instruction manual.



Consult the instructions for use or consult the electronic instructions for use.



The device employs Bluetooth wireless technology.



The device model number.



The device serial number.



The date of manufacture of the device and the name and address of the manufacturer.



Indicates a medical device.



The authorized representative in Switzerland.



The authorized representative in the European Community.



The responsible person in the United Kingdom.

International Contact Information



Manufacturer

Prentke Romich Company
1022 Heyl Rd
Wooster, OH 44691 USA
Tel.: +1 330 262-1984 · +1 800 262-1984
Fax: +1 330 262-4829
Email: info@prentrom.com
Web: www.prc-salttillo.com/



EU Authorised Representative

Prentke Romich GmbH
Karthäuserstr. 3
D-34117 Kassel Germany
Tel.: +49 (0) 561 7 85 59-0
Fax: +49 (0) 561 7 85 59-29
Email: info@prentke-romich.de
Web : www.prentke-romich.de/



EU Importer

Prentke Romich GmbH
Karthäuserstr. 3
D-34117 Kassel Germany
Tel.: +49 (0) 561 7 85 59-0
Fax: +49 (0) 561 7 85 59-29
Email: info@prentke-romich.de
Web : www.prentke-romich.de/



UK Responsible Person and Importer

Liberator Ltd
"Whitegates", 25-27 High Street
Swinstead, Lincolnshire NG33 4PA UK
Tel.: +44 (0) 1733 370 470
Fax: +44 (0) 1476 552 473
Email: info@liberator.co.uk
Web: www.liberator.co.uk/

Authorised Representative in Australia

Liberator Pty Ltd
265, Gilbert Street,
Adelaide, SA 5000 Australia
Tel: +61 (0) 8 8211 7766
Email: info@liberator.net.au
Web: www.liberator.net.au/